

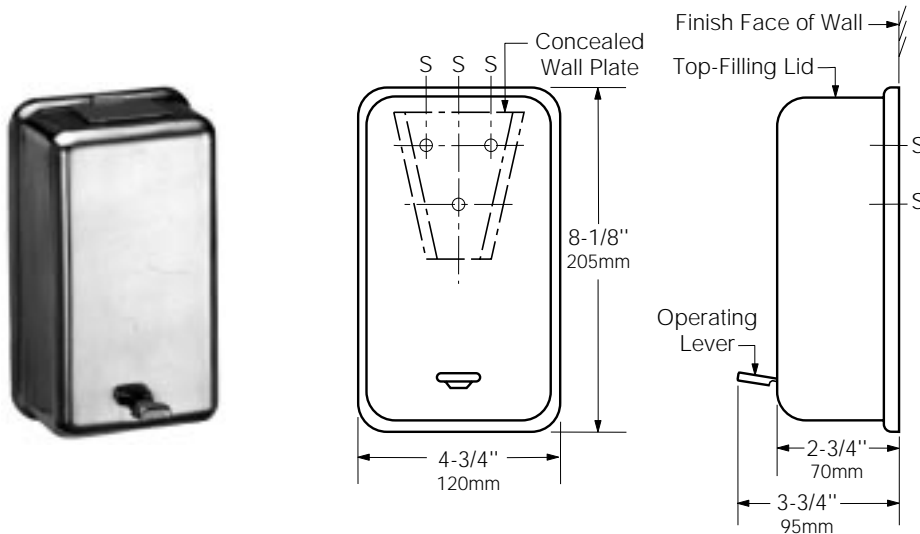

Technical Data

POWDERED SOAP DISPENSER

B-132



MATERIALS:

Container — 18-8 S, type-304, 20-gauge (0.9mm) stainless steel with satin finish. Body is drawn, one-piece, seamless construction. Equipped with a locked, hinged stainless steel lid for top filling. Back is 22-gauge (0.8mm) stainless steel with 20-gauge (0.9mm) stainless steel concealed mounting bracket attached. Furnished with a concealed wall plate. Capacity: 32 fl oz (0.9 L).

Mechanism — Stainless steel lever and soap agitator.

OPERATION:

Push lever down to dispense adjustable amount of powdered soap as regulated by adjustment screw. Spring mechanism agitates soap at each stroke of lever. Unit dispenses any free-flowing powdered soap. Lever operates with one hand, without tight grasping, pinching, or twisting of the wrist, and with less than 5 pounds of force (22.2 N) to comply with barrier-free accessibility guidelines (including ADAAG in U.S.A.). Vandal-resistant, hinged, locked, top-filling lid opens with special key provided.

INSTALLATION:

Secure wall plate to the wall with three sheet-metal screws, furnished by manufacturer, at points indicated by an S. For plaster or dry wall construction, provide concealed backing to comply with local building codes, then secure unit with sheet-metal screws furnished. For other wall surfaces, provide fiber plugs or expansion shields for use with sheet-metal screws furnished, or provide 1/8" (3mm) toggle bolts or expansion bolts.

Note: Provide 4" (100mm) minimum clearance from the lid to the underside of any horizontal projection.

SPECIFICATION:

Soap dispenser shall be type-304 stainless steel with satin finish. Valve with stainless steel lever shall dispense any free-flowing powdered soap and shall have adjustable per-stroke output. Lever shall be operable with one hand and with less than 5 pounds of force (22.2 N) to comply with barrier-free accessibility guidelines (including ADAAG in U.S.A.). Stainless steel agitator-spring shall prevent soap buildup. Container shall be equipped with a locked, hinged stainless steel lid for top filling. Unit shall have concealed, vandal-resistant mounting and shall have a capacity of 32 fl oz (0.9 L). Manufacturer's service and parts manual shall be provided to the building owner/manager upon completion of project.

Powdered Soap Dispenser shall be Model B-132 of Bobrick Washroom Equipment, Inc., Clifton Park, New York; Jackson, Tennessee; Los Angeles, California; Bobrick Washroom Equipment of Canada Ltd., Scarborough, Ontario; Bobrick Washroom Equipment Pty. Ltd., Australia; and Bobrick Washroom Equipment Limited, United Kingdom.