

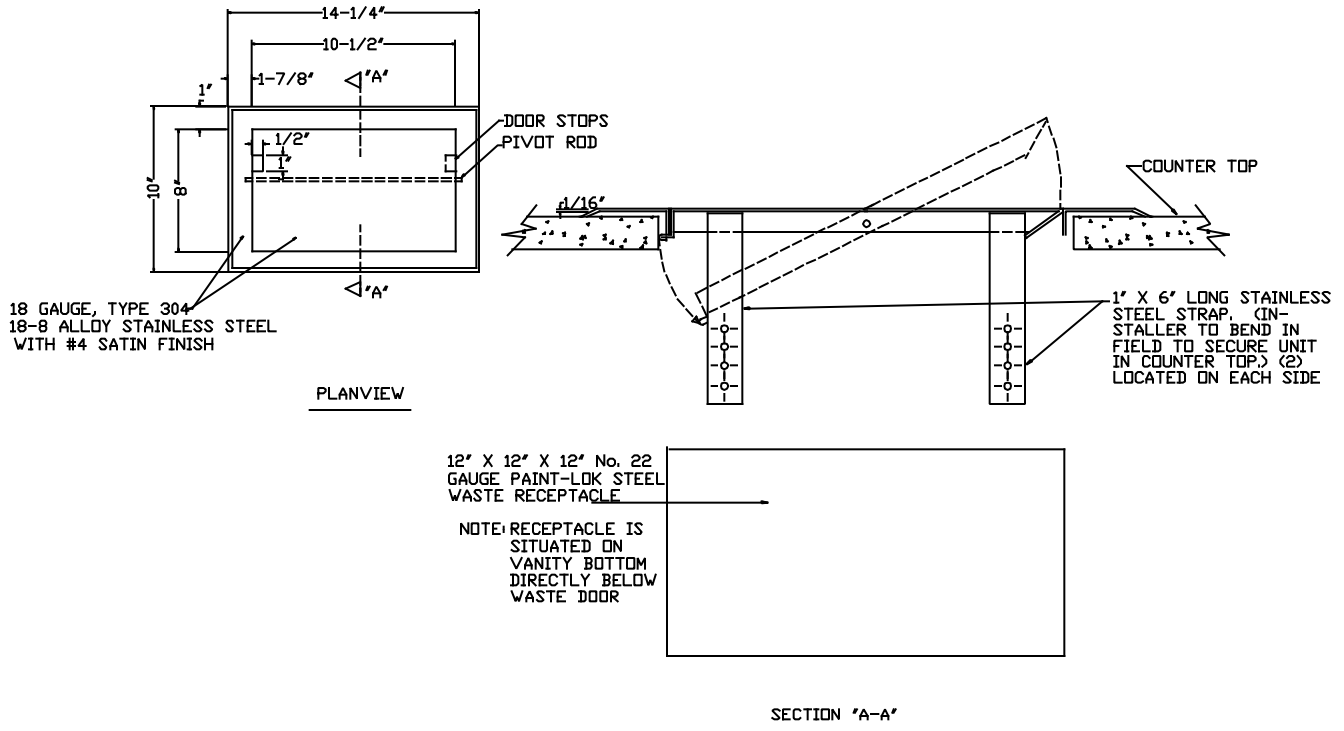

AMERICAN SPECIALTIES, INC.
441 Saw Mill River Road, Yonkers, NY 10701 (914) 476-9000

MODEL No:	1003
ISSUED:	1-87
REVISED:	9-96

WASTE RECEPTACLE ACCESS DOOR WITH WASTE CAN



SPECIFICATION

Waste Receptacle Access Door With Waste Can for counter top installation shall receive 1cu.ft. (0.3m³) or 7.5 gal. (28 liters) of solid waste into loose waste can. Door and face trim shall be fabricated of alloy 18-8 stainless steel, type 304, N^o18 gauge. All exposed surfaces shall have N^o4 satin finish and shall be protected during shipment with PVC film easily removable after installation. Face trim shall be one piece construction with no miters or welding. Adjustable stainless steel mounting straps shall accommodate counter thickness from 1/2" to 4" (13mm to 102mm) thick. Waste receptacle shall be provided loose and shall be all welded construction fabricated of corrosion protected steel N^o22 gauge. Downward finger pressure shall open pivoting waste door for disposal of used paper towels into waste receptacle. Waste door shall return to closed position when pressure is removed.

Waste Receptacle Access Door with Waste Can shall be Model N^o1003 as fabricated by American Specialties, Inc., 441 Saw Mill River Road, Yonkers, New York 10701-4913.

INSTALLATION

Position unit into appropriate counter top cutout (by others). Installer to bend mounting straps upward to suit counter top thickness. Secure mounting straps to underside of counter top with mounting screws (supplied).

Counter top opening required is 8-3/4"H x 12-1/2"W (222mm x 318mm).

OPERATION

Waste is inserted through the swinging door by downward pressure. When pressure is released the waste door returns to its closed position. Waste can is manually emptied on a cycle determined by maintenance needs.

Accessory Specialties

AMERICAN DISPENSER

Desert Ray Products

WATROUS INC.