



AMERICAN SPECIALTIES, INC.
 441 Saw Mill River Road, Yonkers, NY 10701 (914) 476-9000

MODEL No: 1001

ISSUED: 1-87

REVISED: 9-96

FREE-FLOW TOWEL & WASTE (pg1/2)

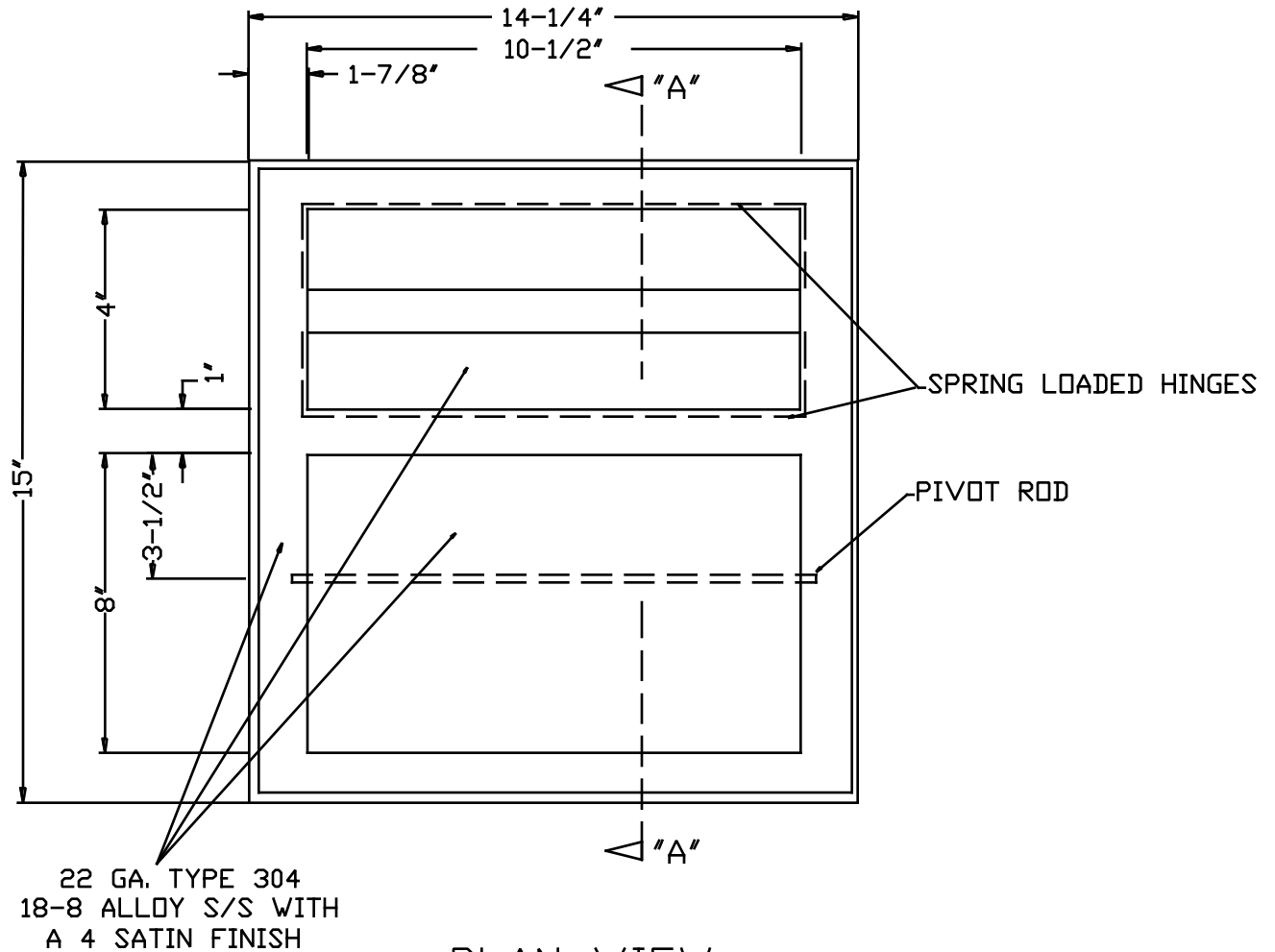

PLAN VIEW

SPECIFICATION

Free-Flow Towel Dispenser & Waste Disposal unit for counter-top mounting shall hold and dispense one (1) package of C-fold paper towels and shall receive 1 cu.ft. (.03m³) or 7.5gal. (28 liters) solid waste. Top frame shall be fabricated of one piece alloy 18-8 stainless steel, type 304, N^o22 gauge. All exposed surfaces shall have N^o4 satin finish and shall be protected during shipment with a PVC film easily removable after installation. Adjustable stainless steel mounting straps shall accommodate counter thickness from 1/2" to 4" (13mm to 102mm) thick. Waste receptacle shall be welded construction fabricated of corrosion protected steel N^o22 gauge. Flap doors shall have rolled edges and shall be mounted on heavy duty spring loaded hinges, and shall have the international graphic waste symbol affixed on it. Waste receptacle shall be provided loose for placement on cabinet floor or shelf directly underneath waste flap doors. Downward finger pressure shall open pivoting waste door for disposal of used paper towels and waste door shall return to closed position when pressure is removed. Towel compartment shall be spot welded to top frame and be corrosion protected steel N^o22 gauge. Spring actuated towel carrier mechanism shall maintain constant dispensing pressure.

Free-Flow Towel & Waste shall be Model N^o1001 as fabricated by American Specialties, Inc., 441 Saw Mill River Road, Yonkers, New York 10701-4913.

Accessory Specialties

AMERICAN DISPENSER

Desert Ray Products

WATROUS INC.



AMERICAN SPECIALTIES, INC.
441 Saw Mill River Road, Yonkers, NY 10701 (914) 476-9000

MODEL No: 1001

ISSUED: 1-87

REVISED: 9-96

FREE-FLOW TOWEL & WASTE (pg2/2)

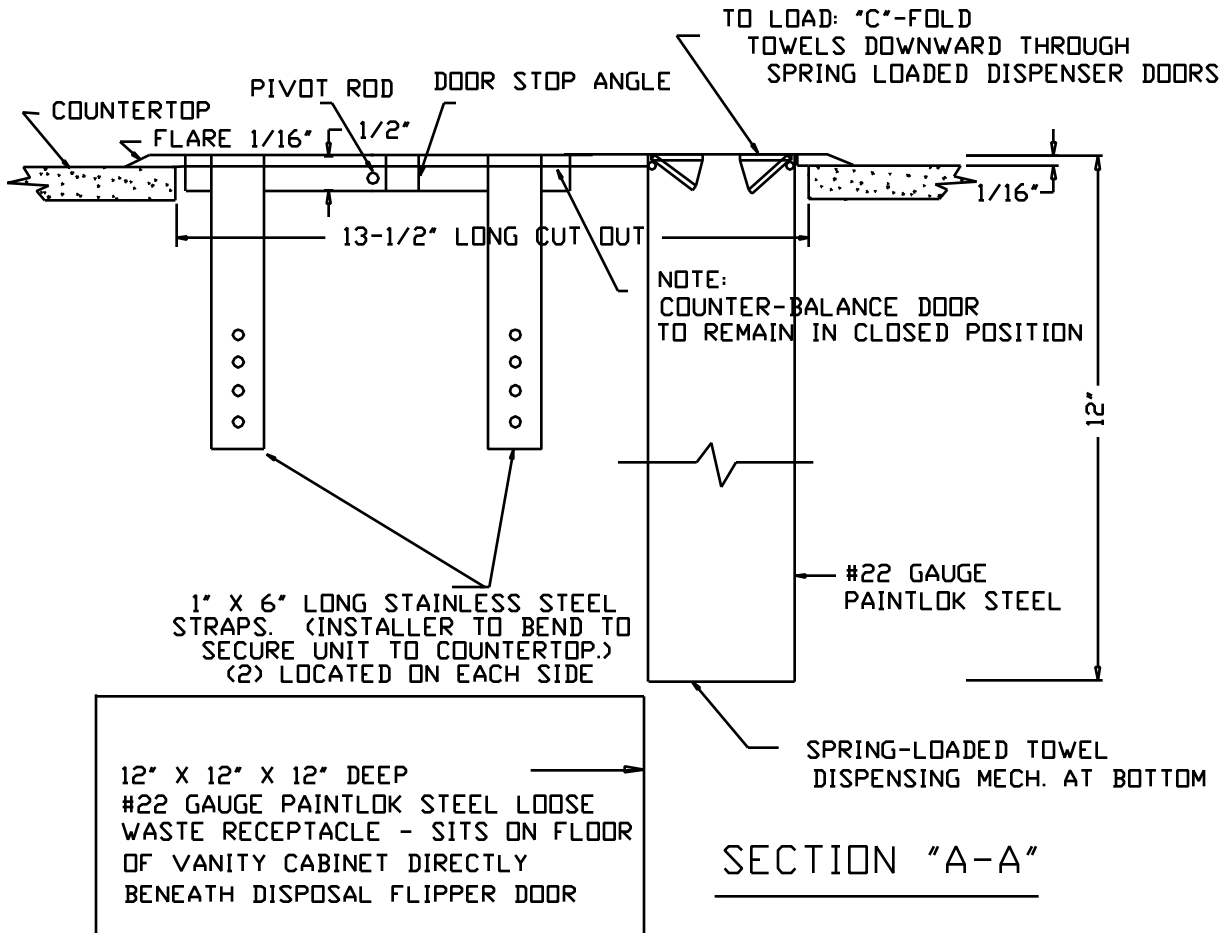

INSTALLATION

Position unit into appropriate counter top cutout (by others). Installer to bend mounting straps upward to suit counter top thickness. Secure mounting straps to underside of counter top with mounting screws (supplied).

Counter top opening required is 12-1/2" W x 13-1/2" L (318mm x 343mm).

OPERATION

Waste is inserted through swinging door by downward pressure. When pressure is released the waste door returns to its closed position. Paper towels are dispensed manually through flap doors. A spring actuated towel carrier mechanism maintains constant towel dispensing pressure. Dispenser is refilled by pushing paper towels downward through flap doors. Waste can is manually emptied on a cycle determined by maintenance needs.

Accessory Specialties

AMERICAN DISPENSER

Desert Ray Products

WATROUS, INC.