



AMERICAN SPECIALTIES, INC.

441 Saw Mill River Road, Yonkers, NY 10701 (914) 476-9000

MODEL No: 0010

ISSUED: 1-87

REVISED: 7-99

CORNER SHOWER STALL SEAT

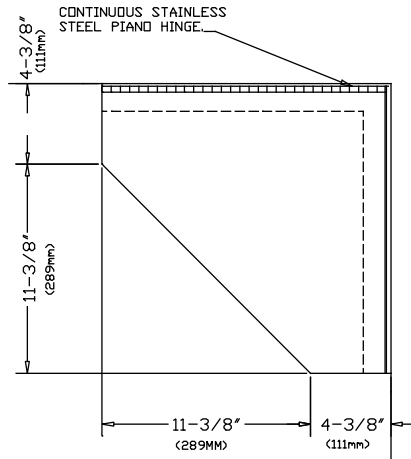

TOP VIEW

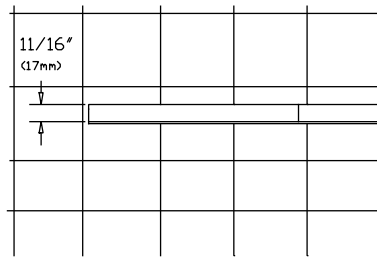

FRONT VIEW (SEAT DOWN)

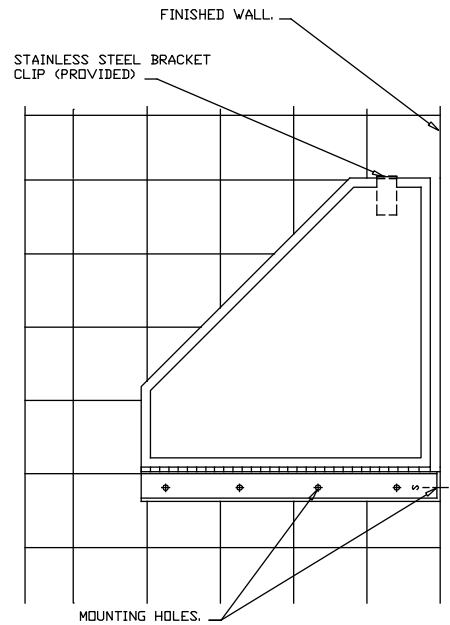

FRONT VIEW (SEAT UP)

SPECIFICATION

Corner Shower Stall Seat with support brackets shall be fabricated of alloy 18-8 stainless steel, type 304, №18 gauge and all exposed surfaces shall have №4 satin finish and be protected during shipment with a PVC film easily removable after installation. Seat shall be fabricated of №16 gauge and shall have all edges and corners beveled, welded, ground smooth and polished. Angle bracket support shall be fabricated of 1/8" (3mm) thick same grade heavy duty stainless steel piano hinge. Structural assembly of all components shall be of welded construction. A stainless steel clip bracket shall be provided to retain seat in storage position. Corner shower stall seat shall be capable of sustaining a weight in excess of 300 pounds.

Corner Shower Stall shall be Model №0010 as manufactured by American Specialties, Inc. 441 Saw Mill River Road Yonkers, New York 10701-4913

INSTALLATION

Mount seat to wall 17"-19" (482mm-483mm) above finished floor (AFF) from top of lowered seat using appropriate fasteners (by others) through counter sunk holes provided in vertical leg of seat bracket. Locate retainer clip bracket to engage seat and hold by friction in storage position. Backing to support seat must be provided as specified by architect and/or required in accordance with local building codes, before finished wall is applied. For compliance with ADA Accessibility Guidelines, install unit with lowered seat top 17" (432mm) min. AFF to 19" (483mm) max. AFF.

CAUTION

Shower seats are no stronger than the anchors or walls to which they are attached. Shower seats must be firmly and securely attached to sustain the loads they are intended to support.

OPERATION

Disengage the bracket clip and lower the seat to a horizontal position. When not in use, return the seat to its storage position by raising the seat to a vertical position and engaging the bracket clip.

Accessory Specialties

AMERICAN DISPENSER

Desert Ray Products

WATROUS INC.